Liquid Level Monitoring System

Priyanka U Bhadule*, Gouri A Jadhav, Shobha A Patole***, Suvarna S
Zambare****, & Nitin M Maske*******

, **, *, ****, & *****Computer Science & Engineering, SVERI's College of Engineering Pandharpur
Maharashtra.*

ABSTRACT

A liquid level monitoring system include sensor mounted liquid level devices. The problem arises related to wastage of water in the society and also in home. IOT liquid level monitoring is very effective system which will inform user about the level of liquid and will prevent it from wastage of water. To the system makes use of container. For this the system uses float sensor placed over the container to detect to detect the liquid level and compare it with the container's depth. We are going to use LED screen, Wi-Fi modem for sending the message and a buzzer for alarm. The system is powered by a 12V transformer. The LED screen is used to display the status of the level of liquid in the containers. Internet of things it is possible to build simple automation devices that can help reduce the wastage of the liquid like water. To state an example, Cities the more use of the water, water may gets wastage . IOT based Liquid Level Monitoring system that has mechanisms to control the wastage of the water Containers are used in this and every container is fixed to a ultrasonic sensor that is placed over the container. Ultrasonic sensors and monitoring systems , this project it is used to measure depth and liquid level.

KEYWORD: *Internet of Thing (IOT), Buzzer, DcMotor, Floatsensor, Arduino, NodeMCU (8266), Wires, LED, Register.*

1. INTRODUCTION

Liquid Level Monitoring system is a very useful system which will inform the users about the level of liquid and will prevent it from overflowing. To demonstrate this the system makes use of containers. The system makes use of LED screen, Wi-Fi modem for sending data and a buzzer. The system is powered. The LED is connected through wire and when the power supply getit, its start blinking. Thus this system helps to prevent the wastage of water by informing about the liquid levels of the containers .we are using Node MCU for sending the messages and also we are using DC motor. This project is helpful for avoiding the wastage of water and we are going to use two float sensor for detecting the level of water. Dc motor used for the automatic off the wastage of water. Buzzer is used for the sound purpose. Wi-Fi is used for the internet connection purpose with the help Wi-Fi send the message to the mobile. We are using the various devices for our projects. IOT based Liquid level monitoring system is useful for the user to detect the level of any liquid and continuously monitor it – over the

internet. Different types of level sensors like float sensors. We have used two Float sensors placed over the containers to determine the level of liquid, Arduino – that will read the level from these two sensors, and send it using IOT, Arduino is used and it is an open-source hardware and software company, project and user community that designs and manufactures single-board microcontrollers and microcontroller control objects in the physical and digital world. Float sensor is an ideal for use in water tanks and water recycling facilities. These float switches are easy to mount and require a simply screw fitting to the tank. The float switches are constructed of long life high quality materials and will provide many years of operation. We are placing at up side of tank. We are also going to use Buzzer in this project, because when the water gets overflow that time buzzer will give the alarm. Every of the consumer device makes use of the Light Emitting Diode (LED). Once this operation will get understood then add them to project a simple way. This is an simplified explanation of how a LED works and how to select a current limiting resistor. The LED tutorial here is enough to use LEDs in a project, but is not intended to be a through explanation. DC motor, it is small, compact and light. It can be controlled from a micro controller/Arduino using our DC Motor Drivers. Water level DC motor is used for automatic to detect the wastage of water.

2. HISTORY & BACKGROUND

The history of liquid level monitoring system is that the people doesn't wastage understand water gets overflow and then water may be. Level sensors was used to monitor and regulate levels of a water. These levels are liquid, however level sensors can also be used to monitor. Level sensors are widely used in industrially. Previously people are manually off the switches which are time consuming and without giving the attention towards it the water get overflow and it get wastage. In our country or most of the areas people are getting less amount of water for use. So we have to save the water for that purpose Liquid Level Monitoring Project which is develop throught the IOT is useful. In most of the company use the liquid level sensors to monitor a level's of a liquids that is water and occasionally also specialist found fluids such as power steering fluid. They can also be in industrial storage tanks, and in household appliances. Basic level sensors can be used to identify the point at which a usually liquid falls below a minimum or rises above a maximum level. Most of the sensors can detail the specific amount of a liquid in a container relative to the levels of the liquid, to provide a continuous measurement of volume. The history of liquid monitoring system in India and its people are complicated linked to the water resources which are available from tanks. These water resources available through tanks are one of the main sources available for the usage to industries, livestock, irrigation, homes etc. and there is a critical need to ensure the safety of the water level at these against any natural or anthropogenic threats and to develop an effective Liquid Level Monitoring system using IoT. This paper also proposes a idea of collecting and sharing real-time information about waterlevels to an authorized central command center through far field communication. Arduino was born at the Ivera Institute as an easy tool for fast prototyping, aimed at students without a background in electronics and programming. It is very useful in iot. The Arduino board was started changing to accept new challenges for IoT applications. In last few years back Arduino has been the brain of thousands of projects, from everyday objects to complex scientific instruments. The community of makers - students, hobbyists, artists, programmers, and profession.

3 .SYSTEM DESIGN

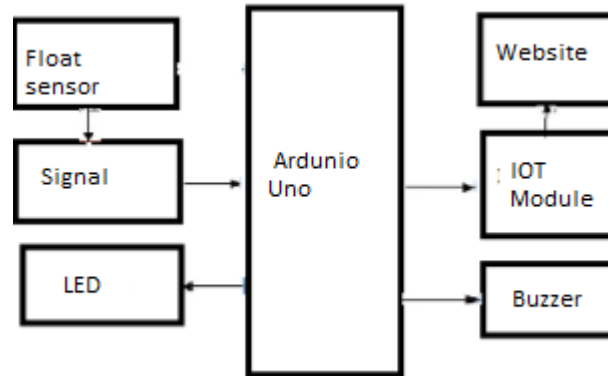

Fig. 1. Block Diagram of IOT based liquid level monitoring

The above block diagram shows that the Arduino Uno is the main part or heart, in that the float sensor plays the role of stopping overflow. The purpose of the signal is that when the water overflows, the signal will be generated. The buzzer is used for alarm purposes to alert the user.

- a.) Processing Unit: An Arduino Uno with an ATmega controller is required for this purpose. The microcontroller will be associated with the greater part of different equipment units in the module. This module takes simple parameters from those sensors, monitors the liquid level, and changes them to advanced yield. This module additionally overcomes the wastage of liquid like water, which sends the sensor's changed information to an advanced mobile telephone.



Fig- Microcontroller

Microcontroller-- The Uno is a microcontroller board based on the ATmega328P. It has 14 digital pins, 6 analog inputs, a 16 MHz quartz crystal, a USB connection, a power jack, an ICSP header and a reset button. The microcontroller simply connecting it to a computer with a USB cable or powering it with a AC-to-DC adapter or battery is enough to get it started. Having its own memory unit and processor, microcontrollers or mini computers are used to implement the entire software using the hardware. ARDUINO UNO, is used to process the information or data in a very simple way. Also a Raspberry Pi, a full-fledged computer, generally operating on Linux OS, is used to run the program codes. Since Raspberry Pi cannot read any analog signal, ARDUINO is used as an interface between them.

4. RESULT AND ANALYSIS

[1] It has reached its objective in developing the monitoring system. The level of water is displayed in the LEDs used as indicators also turns on and off depending on the level value of water. The LED tracks the previous measurements.

[2] has implemented a system possible for monitoring the level of water in a tank, switch on the pump when the tank is empty and switch off without any need for human intervention when the tank is full. Thus, eliminating water wastage and frequent cut-off of water supply.

5. CONCLUSION

The liquid level monitoring system is helpful for the people who are working in the industry or living in the house etc for all of them it is helpful because it saves the water also the electricity and reduce the human efforts. So this project we are developed through IOT for protecting the water from wastage.

6. REFERENCES

- i. P.Dietz , W. Yerazunis, D. Leigh, veryLow-cost sensing & Communication Using Bidirectional LED'S UbiComp,2011: proceeding 5, Vol.2864, pp.175_''191,2003.
- ii. JagedeshBoopathi, "555 timer based water level controller" Electorinic Tutorial byJagan Sindha,Inc.,23 June 2013.
- iii. <http://ece.jagansindia.in/2013/06/555-timer,based water level controller>.
- iv. Microcontroller Based Automated Water Level Sensing and Controlling: Design and Implementation Issue Proceedings of the World Congress on Engineering and Computer Science, pp 220-225.
- v. P. Dietz, W. Yerazunis, D. Leigh, Very Low -Cost Sensing and Communication Using Bidirectional LEDs, UbiComp 2011: Proceedings, vol. 2864, pp. 175`-191, 2003.

-
- vi. Asaad Ahmed Mohammed ahmed Eltaieb1, Zhang JianMin2 .“Automatic Water Level Control System”, International Journal of Science and Research (IJSR) ISSN (Online): 2319-7064.
 - vii. NiteenMohod, “Usability of Internet of Things [IoT] For Dam Safety and Water Management”, International Journal of Research in Advent Technology, Vol.5, No.1, January 2017.
 - viii. A.C. Khetre, S.G. Hate, “Automatic monitoring & Reporting of water quality by using WSN Technology and different routing methods”, IJAR CET Vol 2, Issue 12, Dec 2013, pp 3255- 3260.

7 ACKNOWLEDGMENTS

We would like to thank the administration and management at SVERI's College of Engineering Pandharpur for providing us the support and encouragement required to carry out the work. We extend our sincere thanks to Mr. N. M. Maskewho continuously helped us throughout the implementation and without his guidance, this project would have been an uphill task.

www.ijmas.com